

Elite 440

Multi-line three-phase panel meter



Add on
modules



High
accuracy



Modbus
communication

MFM with high accuracy, configurability and easy integration

Elite 440 is a multi-line three-phase digital panel meter for accurate and reliable measurement of electrical parameters (voltage, current, power, frequency, etc.) for industrial and commercial applications. It has a large multi-line backlit LCD display which enables four parameters to be displayed at the same time. Modbus communication capability allows easy integration with energy monitoring systems. Expansion modules can be fitted for enhanced system integration (pulse inputs/outputs or analogue output and ethernet).



Application

- Commercial and industrial sub-metering and Energy Management System (EMS) applications
- Building management and monitoring systems (BMS)
- High, medium and low-voltage switchgear panels
- Control and relay panels
- Power Control Centre (PCC) panels
- Motor Control Centre (MCC) panels
- Relaying and control outputs
- Plant automation and monitoring system (SCADA/DAS)

Benefits

- Easy interface with external devices through built-in Modbus (RS-485/Ethernet)
- Detachable connectors for easy installation
- Diagnostics assistance on display
- Suitable for star or delta connections and for low or high-voltage applications
- Cost-effective online monitoring
- Field-configurable CT/PT primary and secondary values using push-buttons

Feature

- Large four-line seven-digit display (9.7 H x 5 W mm) with quadrant identification section and bar graph for instantaneous power-level indication
- High accuracy: Class 0.2s, 0.5s, 1.0
- Average THD measurement for voltage, current and power, up to 31st harmonic
- Measurement selection (star or delta/3P4W or 3P3W)
- Modbus communication via RS-485 port/ethernet
- True root-mean squared (RMS) metering
- Calibration LED for accuracy test on site
- Wide and configurable current range 1-2A and 5-10A
- Wide-range auxiliary power supply, suitable for high-voltage or low-voltage installations
- Maximum demand recording
- Midnight snapshot (values) for selected energy registers
- Scroll-lock and 'Favourites Page' display support
- Expansion capability via add on modules for analogue outputs or pulse inputs/outputs and ethernet
- Password protection for setup mode
- Ethernet gateway module for easy integration of multiple meters connected over RS485 network

Elite 440

| Features | Models | | | | | | | |
|---|--------|-----|-----|-----|-----|-----|-----|-----|
| | 441 | 442 | 443 | 444 | 445 | 446 | 447 | 448 |
| P-N voltage | | | | | | | | |
| Average P-N voltage | • | • | • | • | • | • | • | • |
| P-P voltage | • | • | • | • | • | • | • | • |
| Average P-P voltage | • | • | • | • | • | • | • | • |
| Line current (L1, L2, L3 and average) | • | • | • | • | • | • | • | • |
| Active/reactive current | • | • | • | • | • | • | • | • |
| Frequency | • | • | • | • | • | • | • | • |
| Power factor | • | • | • | • | • | • | • | • |
| Average power factor | • | • | • | • | • | • | • | • |
| Active power | | • | • | • | • | • | • | • |
| Total active power | | • | • | • | • | • | • | • |
| Reactive power | | • | • | • | • | • | • | • |
| Total reactive power | | • | • | • | • | • | • | • |
| Apparent power | | | • | • | • | • | • | • |
| Total apparent power | | | • | • | • | • | • | • |
| Active total import/export energy | | | • | • | • | • | • | • |
| Reactive import (Q1+Q2)/export (Q3+Q4) energy | | | • | • | • | • | • | • |
| Reactive (Q1,Q2,Q3,Q4) energy | | | | | • | • | • | • |
| Apparent import/export energy | | | | | | • | | • |
| Active/apparent forwarded energy | | | | | • | | • | |
| Reactive lag/lead forwarded energy | | | | | • | • | • | • |
| Cumulative MD | • | • | • | • | | | | |
| Phase angle | | | • | • | | | | |
| Power on/off hours | | | | • | • | • | • | • |
| Load on/off hours | | | | • | • | • | • | • |
| Feeder interruptions count (when aux is also off) | | | • | • | • | • | • | • |
| Min/max values | | | • | • | • | • | • | • |
| THD voltage | | • | • | • | • | • | • | • |
| THD current | | | • | • | • | • | • | • |
| THD power | | | | | | | • | • |
| RPM with freq and VUnb and IUnb | • | • | • | • | • | • | • | • |
| Modbus on RS 485 | • | • | • | • | • | • | • | • |
| | | • | • | • | • | • | • | • |
| | • | • | • | • | • | • | • | • |

Note:

Ethernet (add on) module is available for all Elite 440 models as single meter module or gateway
 Additional modules (two pulse input & output or four analogue outputs) can be available in Elite 443 to Elite 448
 # Optional software config view is available for reading and configuration



Connection diagram

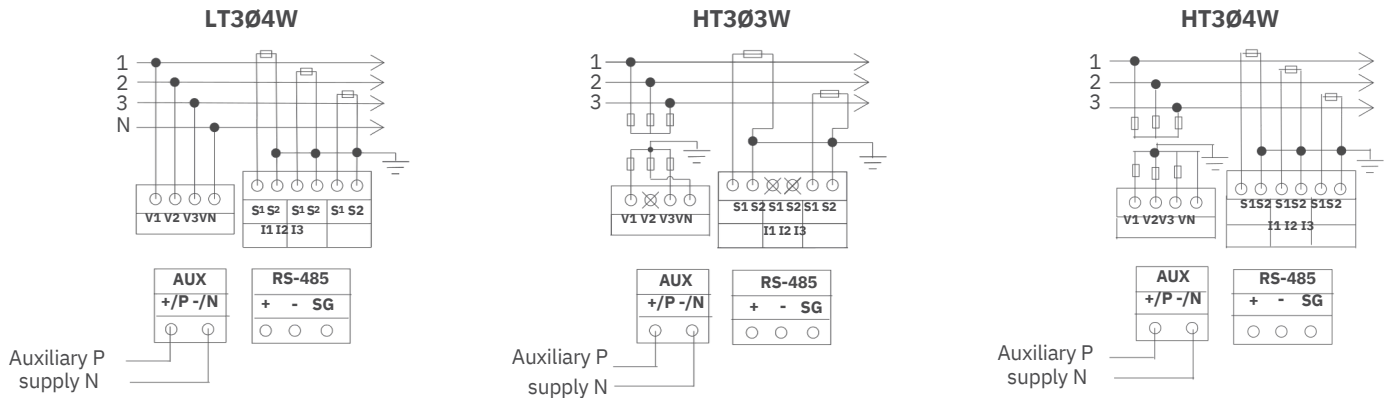

In case of CT/PT operated meter, ensure that meter is connected on secondary side of instrument transformer.

In case of 3Ø3W, VN is replaced by V2.



SHORT CTs BEFORE OPENING CURRENT TERMINALS

Mechanical dimensions

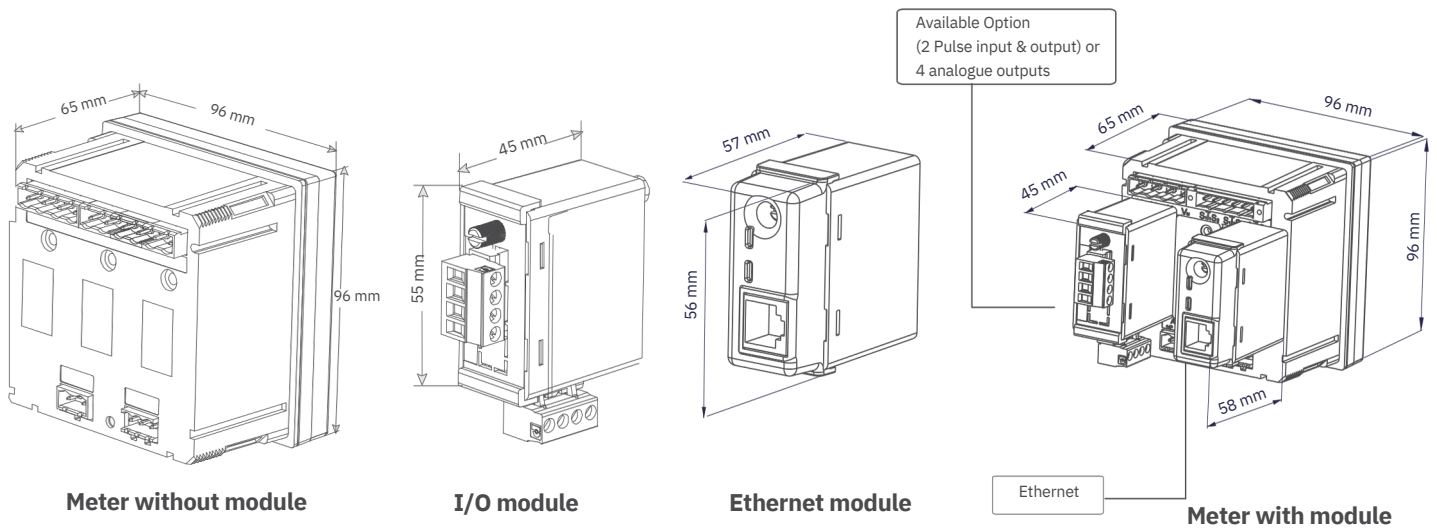



Technical specifications

Electrical

| | |
|---------------------------|--|
| Connection type | Common product for HT3/HT4/LT4 application |
| Voltage range: | |
| Measurement voltage range | 57.7V(100V)-240V(415V)AC3phase4wire(3phase 3 wire) Tolerance-30% to +20% of V_n |
| Aux power supply range | 80 - 300 V AC/DC or 24 - 60 V DC (variant) |
| Current range | Available 1-2A and 5-10 A in single variant (field configurable) |
| Main frequency | 50/60Hz with $\pm 5\%$ |
| Accuracy Class | 0.2s, 0.5s, 1.0 |
| Burden | Auxburden:3.5VA;8VAwhenallmodulesconnected. Currentctburden:1A-0.05VAperphase,5A-0.25 VA per phase. Voltage ckt burden: 0.15 VA per phase. |
| Short time over current | 20 x I_{max} for 1 sec., 10 x I_{max} for 3 sec., 7 x I_{max} for 10 sec. |

Compliance

| | |
|------------|---|
| Standards* | IS13779,IS14697,IEC62052-11,IEC62053-21,IEC62053-23, IEC62053-22, IEC61010, IEC62053-31 |
|------------|---|

Mechanical

| | |
|--------------------|---|
| Dimensions (WXHxD) | 96x96x65mm(w/omodule);96x96x110mm(with module) Cut out size 92 x 92 mm |
| Weight | 0.5 kg (approx) |
| Enclosure | FRPC |
| Terminals | Combicon connector |
| Max conductorsize | 2.5 mm ² |

Environmental

| | |
|--------------------|--|
| Ingress protection | IP 54 (front fascia); IP20 (at terminals) |
| Insulation | 4 kV RMS50Hz, 1 minute |
| Impulse withstand | 6kV |
| Temperature | -20 °C to +60 °C (operating) -25 °C to +80 °C (storage) |
| Humidity | 95% non-condensing |

Features

| | |
|----------------|---|
| Favourite page | On/Off |
| CT/VT primary | Configurable in field through keypad |
| Communication | RS485 Modbus half duplex (default) and data will be available in floating point format (IEEE754) |
| Baud rate | From 1200-38400 bps (Default 9600 bps) |
| Load survey | 40 days for 6 parameters @ 30 minutes integration period Options for 15 or 60-minute integration period. |

Modules

| | |
|---|---|
| 2Digitalpulseinputandoutput(singlemodule) | Input supports voltage range of 8-40VDC with pulse duration of 5 ms for input 1 and 40 ms for input 2. Output are normally open type, voltage rating of 230 V AC @ 100 mA or 48 V DC @ 100 mA with pulse width of 80 ms or 240 ms |
| Ethernet | 10/100base-T for Modbus over TCP/IP communication |
| 4 analogue outputs | Analogue output supports current range of 4-20 mA non-isolated with loop impedance 750 Ω , auxiliary supply 20-40V DC @ 100 mA |